



FEATURES

- Tool free quick change design 6 and 8 port configurations .
- Fits all types of pans and trays up to 18" (46 cm) wide.
- Servo driven (electronic) depositor.
- Integrated conveyor lift motion.
- Programmable touch screen color display with storage for 100 recipes and 7 selectable deposit modes.
- Minimal sanitation and maintenance requirements.
- Large hopper 11 US gal (42 liter) w/ safety cover



MULTISTATION

Electronic Servo Multi Piston Depositing System

Traditional confectionary gearwheel depositors are used worldwide, and are known for performing very well but with limitations in production speed and type of products that they are able to work with.

In these applications the Unifiller **MultiStation M600** and **M800** are the perfect alternate solution to traditional gearwheel confectionary depositors.

Clean deposit relatively viscous to liquid products with and without chunks such as batters, fruit fillings, sauces, delicate mousse fillings, salad dressings, soups, and dairy products.

BAKERY ▶

FOOD ▶

KEY BENEFITS

- High speed production rates.
- Accurate portion control through each nozzle port.
- Smaller minimum portions than pneumatic depositors.
- Deposit chunks and particulate without damage.
- Gentle portioning with less damage on fragile, delicate products.

SYSTEM OPTIONS

- Wide range of nozzles and manifolds to select from
- Optional 360 mechanism for round-cakes and twist rosettes
- Available configuration for injection
- Hopper with optional heater and/or agitator





Continuous Mode



Spread Mode



Chunky Fruit Filling



Éclair Mode

Machine Series	Product Cylinder Size	Deposit Volume (fl oz)			
		Min (5%)		Max	
M600	2" (5 cm)	0.4 oz	(13 ml)	8.7 oz	(255 ml)
M800	1.75" (4.5 cm)	0.3 oz	(10 ml)	6.7 oz	(200 ml)
Small Bore Pistons M600 / M800	1.25" (3.2 cm)	0.2 oz	(5 ml)	3.4 oz	(100 ml)

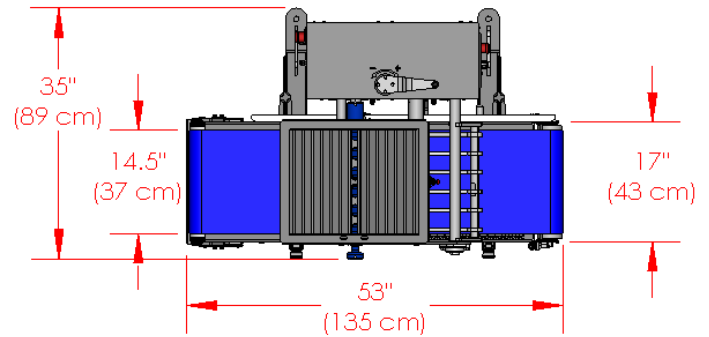

Specifications



SPEED

Up to 120 cycles / min

Based on 20% deposit volume and product consistency



PARTICLE SIZE

Up to 1/2" (13 mm) of soft fruit type fillings.



ELECTRICAL

220 VAC, Single Phase, 15 A, 50-60 Hz (non GFI supply)



AIR

4 CFM @ 80 psi (141.5 L/min @ 6.9 Bar)



SHIPPING INFO

Dimensions: L x W x H

North America:

61 x 39 x 74" (155 x 99 x 188 cm)

Overseas:

58 x 41 x 63" (147 x 104 x 160 cm)

Weight: 800 lbs (360 kg)

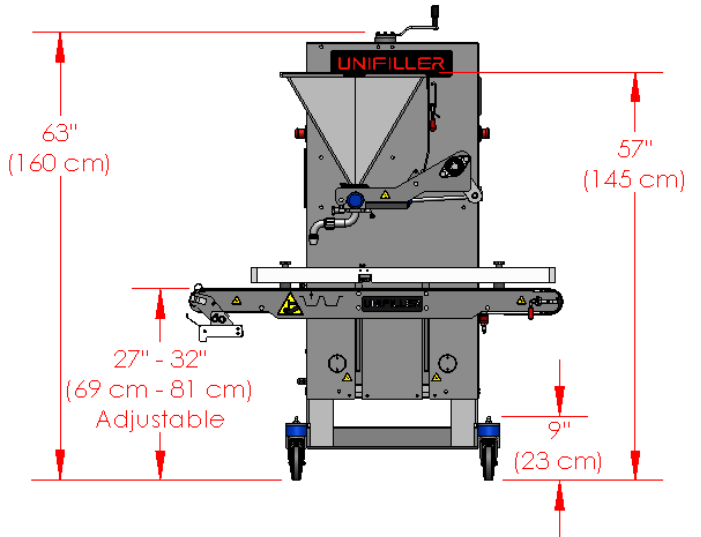





NOTE: Equipment quoted is designed to run at the quoted speed and is dependent on operator efficiency, skill, deposit size and





Accessories

Accessory	Notes
Drip Free Nozzle Stabilizer 	Keeps drip free nozzles located and aligned to a specific center to center. Manual center to center adjustment not required.

Accessory	Notes
Conveyor Extension 	Attached at the infeed of the conveyor, this helps when placing large pans.









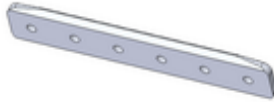

Attachments

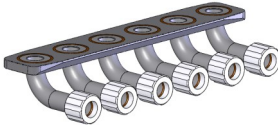
Attachment	Notes
Heated Hopper 	Use the MultiStation with warm products.
Hopper Divider—Marble Cake 	Split the outlets to draw product simultaneously from two chambers. Only available with “Direct from block” nozzles. Typically used for marble cake batter.
Hopper Divider—Split 	Split outlets for depositing two products at the same time side-by-side.
Ring Nozzle 	Deposit batter for mini Bundt cakes.
Low Friction Valves 	Designed specifically for extremely stiff or sticky products.

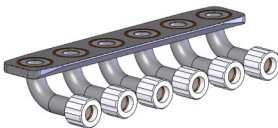
Attachment	Notes
360 Nozzle Pneumatic 	Apply twist rosette decorations on top of cupcakes.
360 Nozzle Servo 	Spread layers of icing on top of round cakes.
Injection Tooling Kit 	Inject muffins with creams and fillings.
Flex Line Production Systems 	Combine MultiStations with conveyors, Single Piston depositors and Hopper Topper pumps to create flexible production systems.

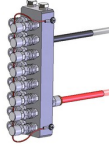
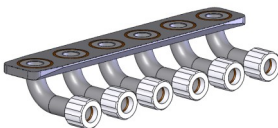
Item	Select	Notes
Base Machine		
MultiStation NA		
MultiStation EU		

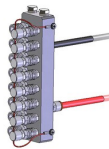
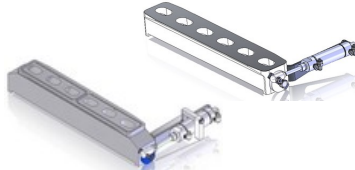
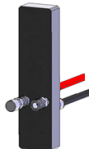
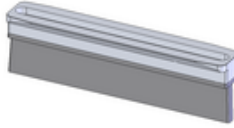
Item	Select	Notes
Product Cylinder Kits		
Hot kits required for product temperatures of 140 - 180 °F (60 – 82 °C)		
M 600 Standard (2" bore)		
M 600 Small Deposit (1.25" bore)		
M 800 Standard (1.75" bore)		
M 800 Small Deposit (1.25" bore)		

Select	Nozzle Setup	Nozzle Adapter and Fixed (Direct from Block) Nozzles	Adjustable Nozzle	Air Distribution Manifold
	Direct from Block Nozzle Plate		Not Applicable	Not Applicable
	Fixed Spout Nozzles with Tip Adapters		Not Applicable	Not Applicable
	Outlet Assembly with Spout Nozzles Minimal Center to Center: 1.7"			Not Applicable
	Outlet Assembly with Rotary Cutoff Nozzles Minimal Center to Center: 2.7"			
	Outlet Assembly with Drip Free Nozzle Minimal Center to Center: 1.75"			
	Rotary Manifold Nozzle Standard: 15.5" spread width Extended: 17.5" spread width		Not Applicable	
	Spreader Nozzle		Not Applicable	Not Applicable
	360 Nozzle Servo Standard attachment can accommodate: - 2 cakes up to 8.3" diameter - 3 cakes up to 4.2" diameter can be custom made with up to 6 outlets			Not Applicable